

CLUTCH DRUM AND INPUT SHAFT ASSEMBLY

COMPONENTS

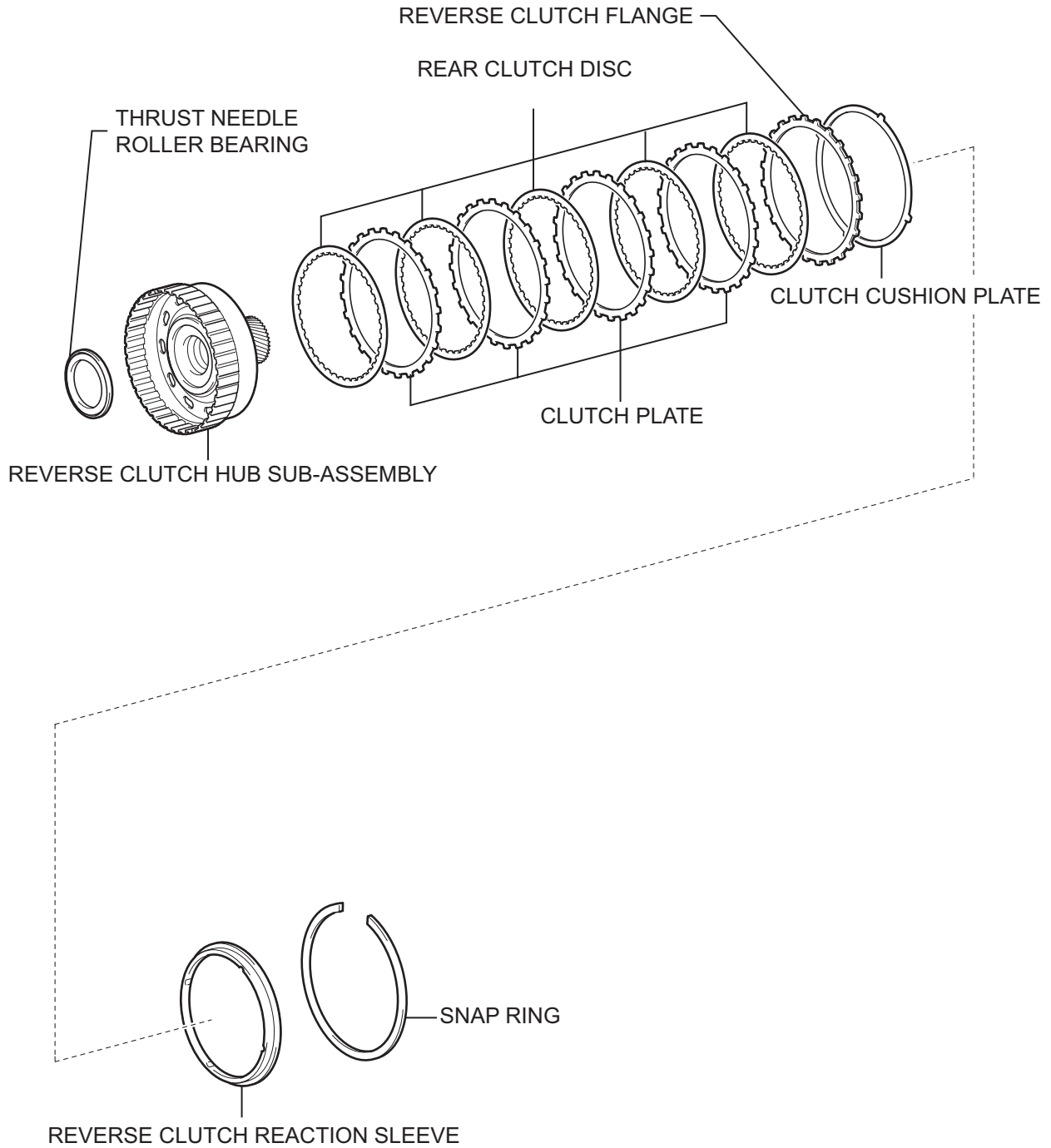

AT

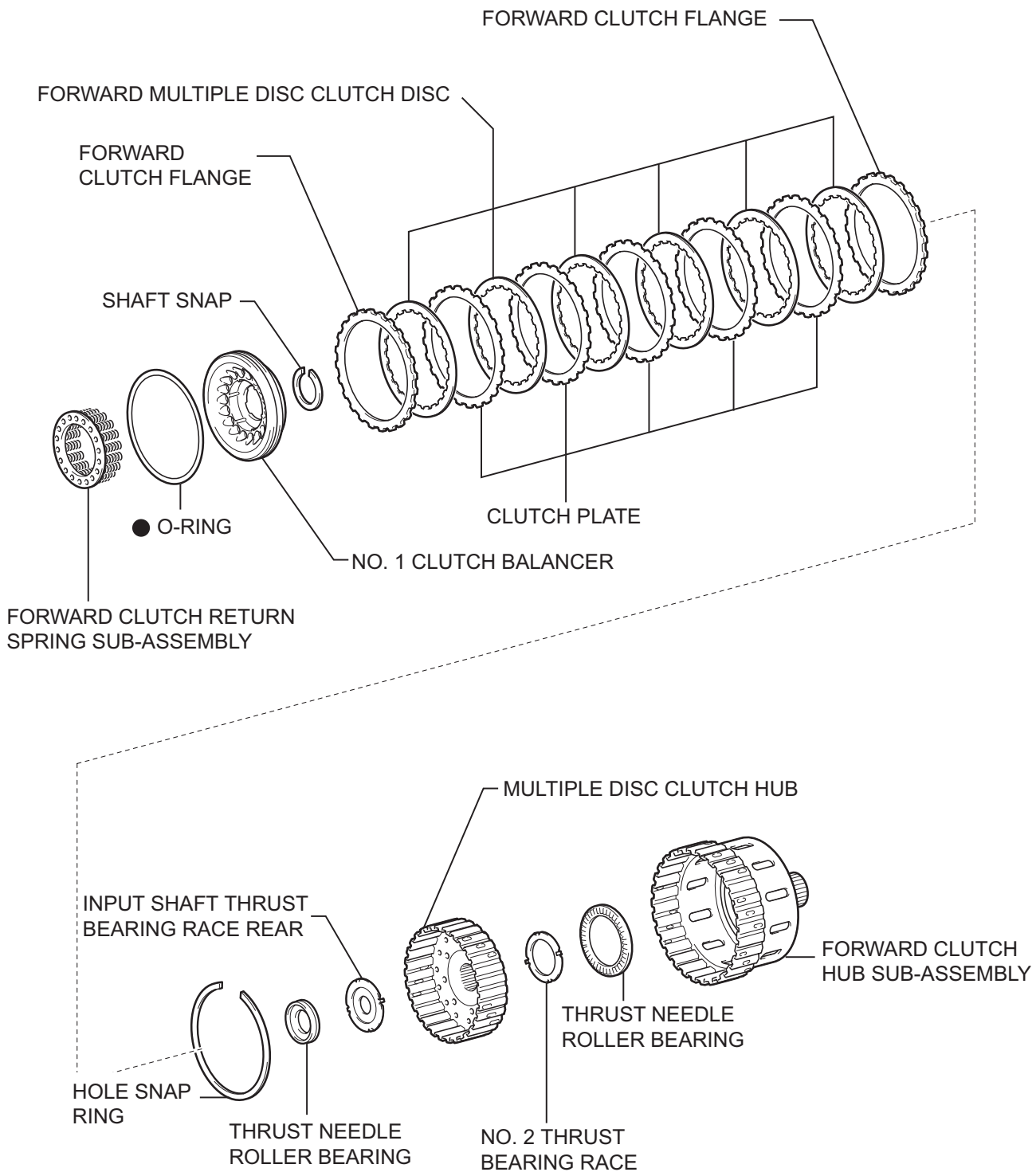

● Non-reusable part

AT

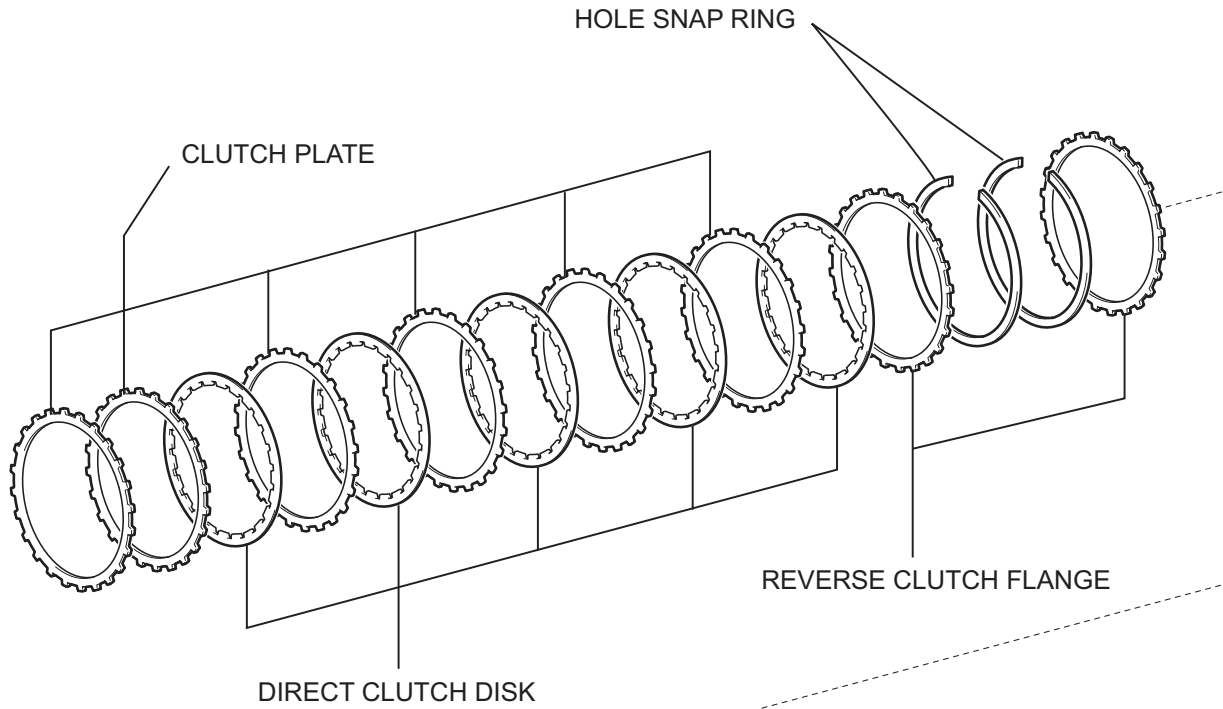

AT

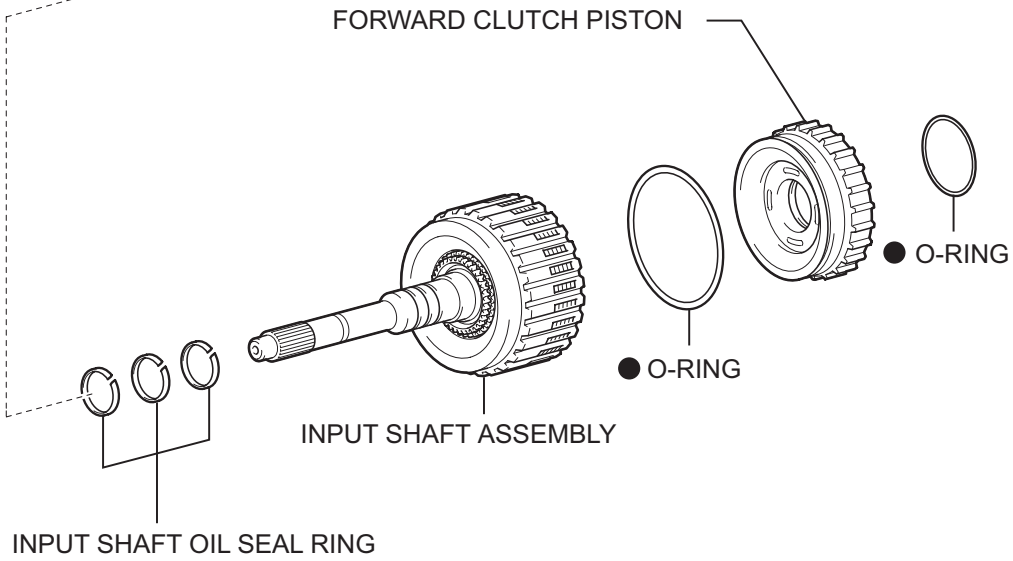

● Non-reusable part

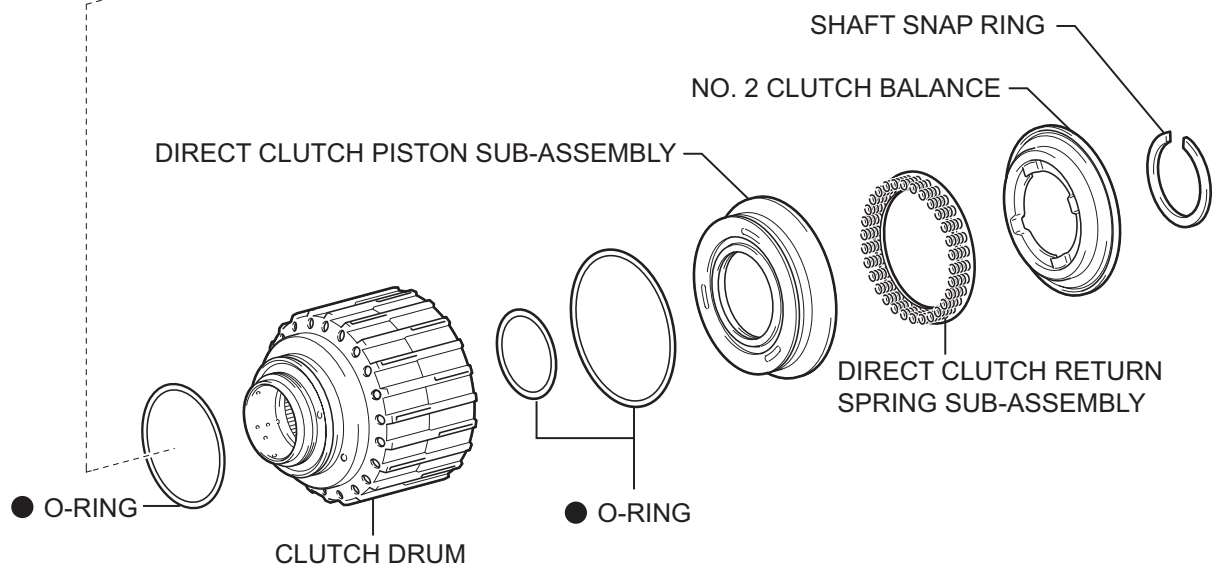
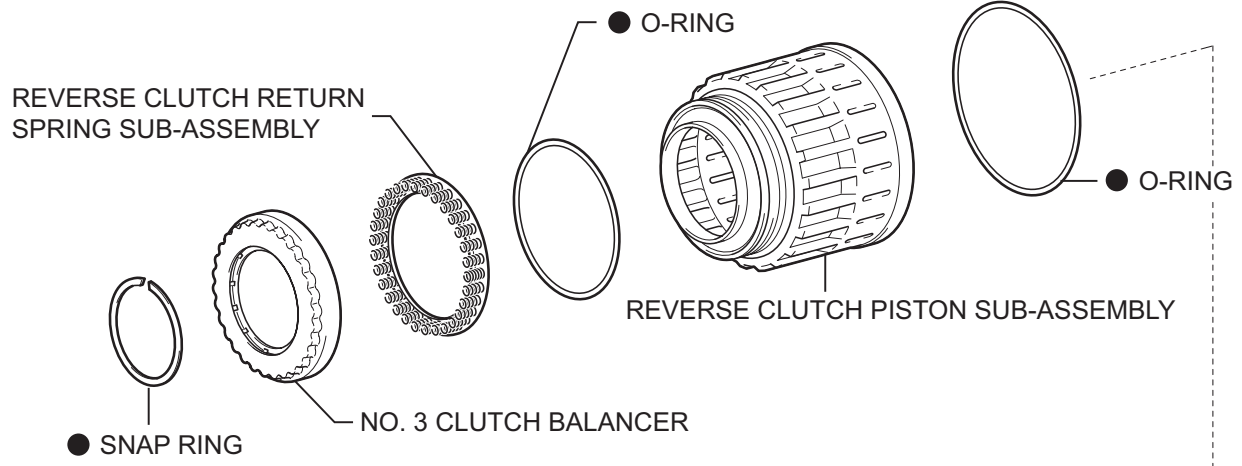

● Non-reusable part

AT

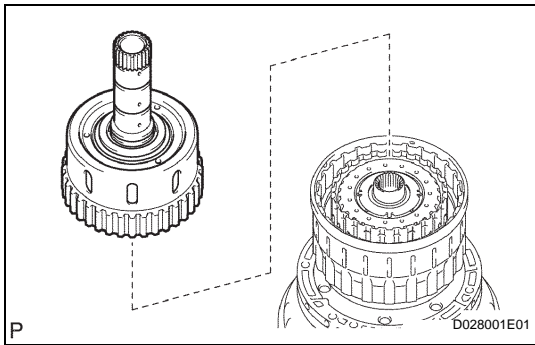

7. REMOVE FORWARD CLUTCH HUB SUB-ASSEMBLY

(a) Remove the forward clutch hub sub-assembly from the clutch drum assembly.

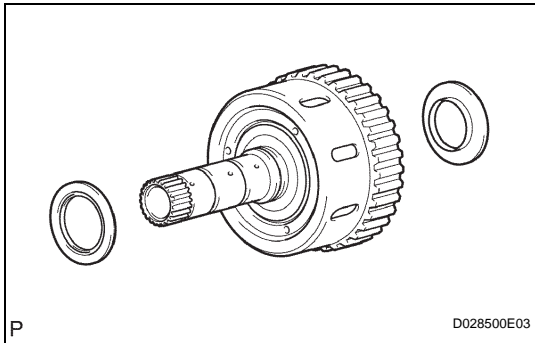

(b) Remove the 2 thrust needle roller bearings from the forward clutch hub sub-assembly.

8. INSPECT FORWARD CLUTCH HUB SUB-ASSEMBLY (See page AT-255)

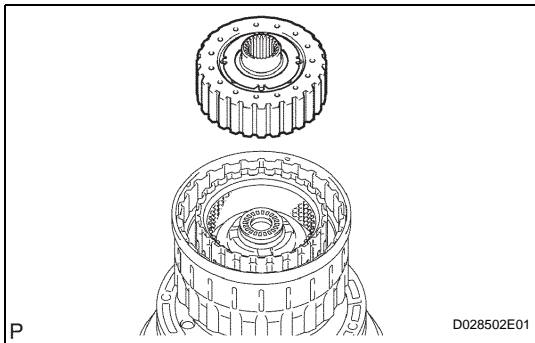

9. REMOVE MULTIPLE DISC CLUTCH HUB

(a) Remove the multiple disc clutch hub from the clutch drum assembly.

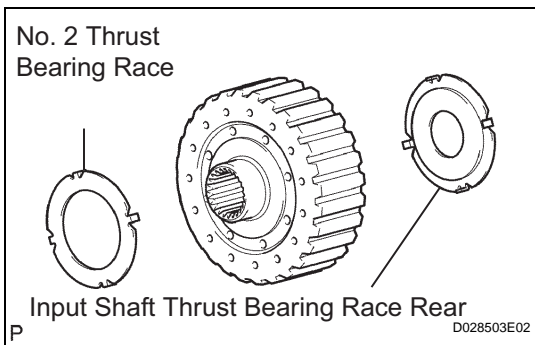

(b) Remove the No. 2 thrust bearing race and input shaft thrust bearing race rear from the multiple disc clutch hub.

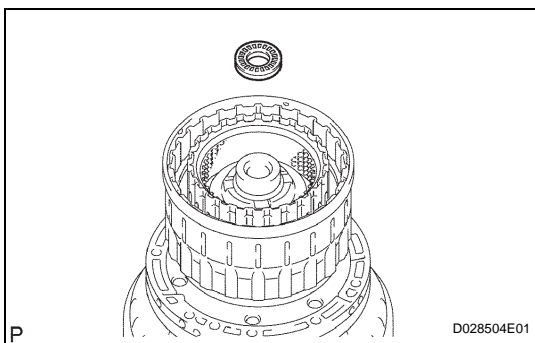

10. REMOVE INPUT SHAFT ASSEMBLY

(a) Remove the thrust needle roller bearing from the clutch drum assembly.

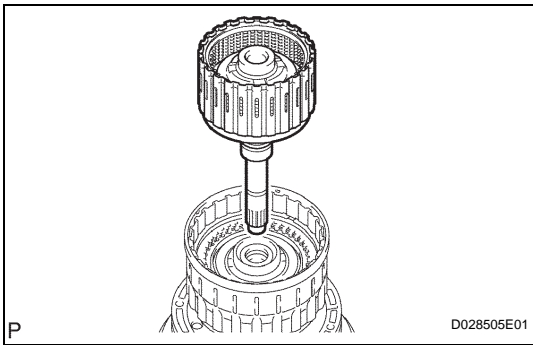

(b) Remove the input shaft assembly from the clutch drum assembly.

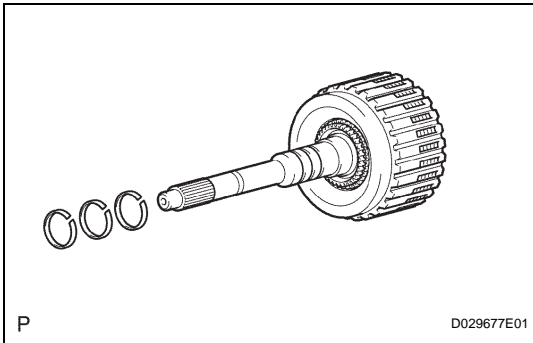

11. REMOVE INPUT SHAFT OIL SEAL RING

(a) Remove the 3 oil seal rings from the input shaft assembly.

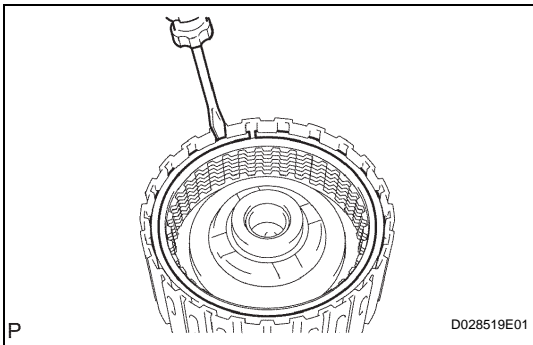

12. REMOVE FORWARD MULTIPLE DISC CLUTCH DISC

(a) Using a screwdriver, remove the hole snap ring.

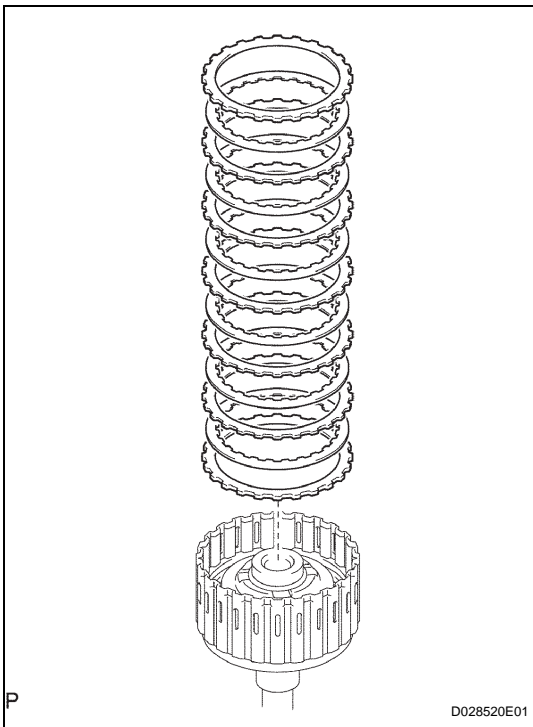

(b) Remove the 2 flanges, 6 discs and 5 plates from the input shaft assembly.

13. INSPECT FORWARD MULTIPLE DISC CLUTCH DISC (See page AT-255)

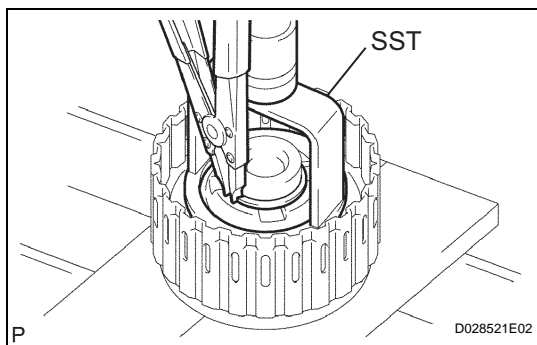
**14. REMOVE NO. 1 CLUTCH BALANCER**

- (a) Place SST on the No. 1 clutch balancer, and compress the return spring with a press.
SST 09350-30020 (09350-07040, 09350-07070)

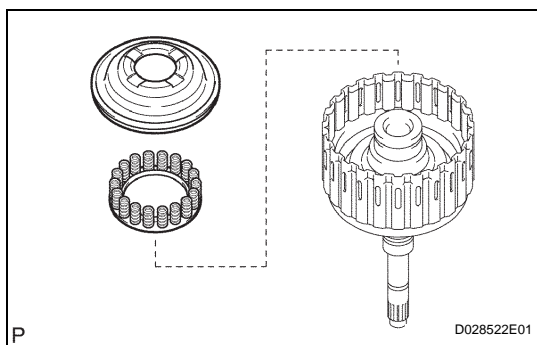

- (b) Remove the No. 1 clutch balancer and forward clutch return spring from the input shaft assembly.

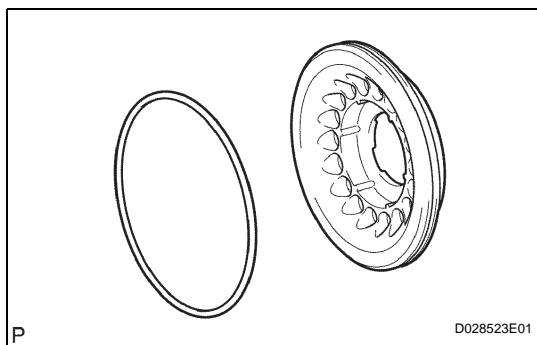

- (c) Remove the O-ring from the No. 1 clutch balancer.

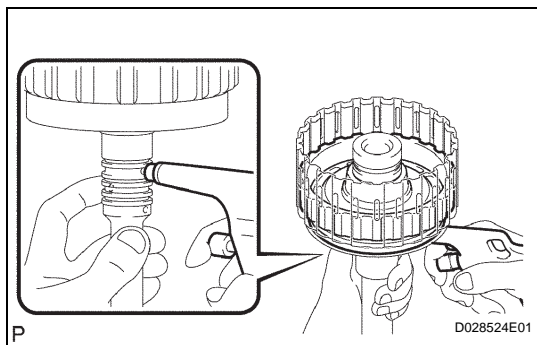
15. INSPECT FORWARD CLUTCH RETURN SPRING SUB-ASSEMBLY (See page AT-255)**16. REMOVE FORWARD CLUTCH PISTON**

- (a) Holding the forward clutch piston by hand, apply compressed air (392 kPa, 4.0 kgf/cm², 57 psi) to the input shaft to remove the forward clutch piston.

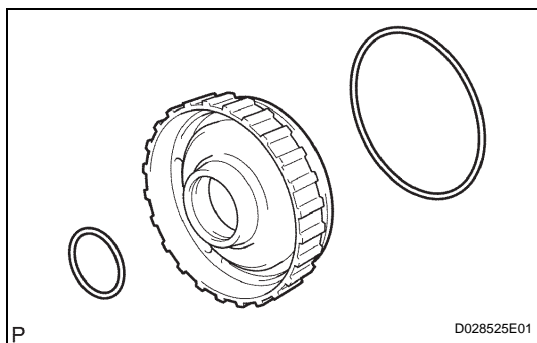

- (b) Remove the 2 O-rings from the forward clutch piston.

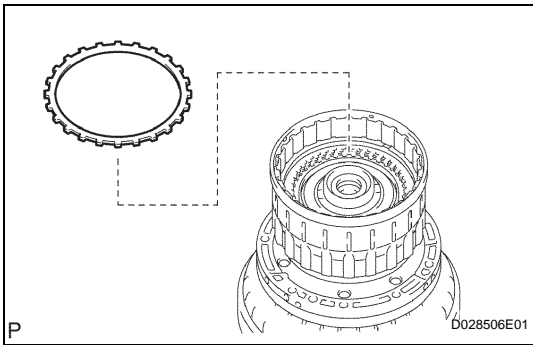

17. REMOVE REVERSE CLUTCH FLANGE

- (a) Remove the reverse clutch flange from the clutch drum assembly.

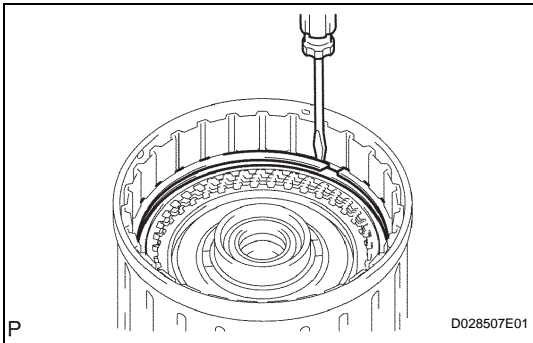

18. REMOVE DIRECT CLUTCH DISK

- (a) Using a screwdriver, remove the 2 hole snap rings from the clutch drum assembly.

- (b) Remove the reverse clutch flange, 6 plates and 5 discs from the clutch drum assembly.

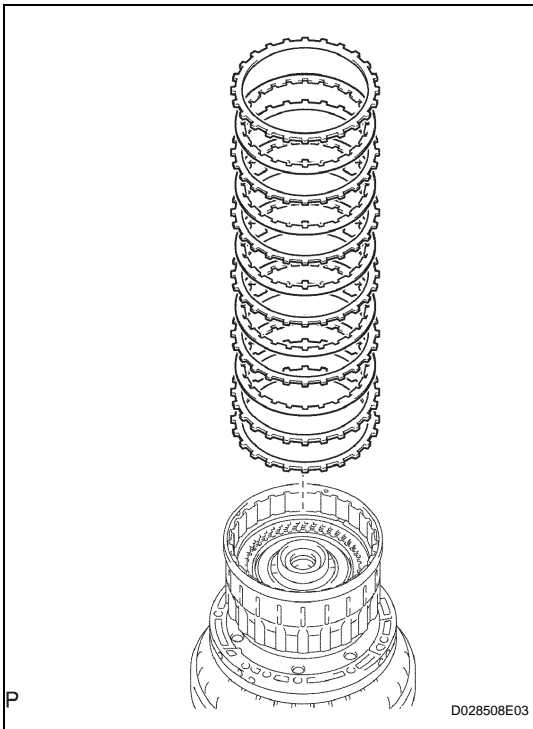

19. INSPECT DIRECT CLUTCH DISK

AT

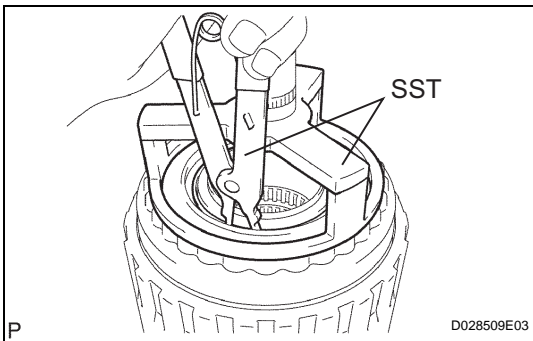

20. REMOVE NO. 3 CLUTCH BALANCER

- (a) Place SST on the No. 3 clutch balancer, and compress the return spring with a press.
SST 09387-00070, 09350-30020 (09350-07070)
- (b) Remove the snap ring.

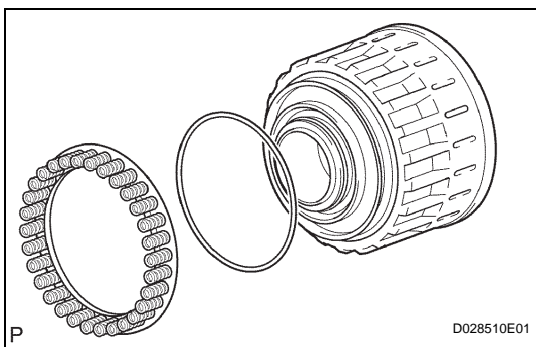

21. REMOVE REVERSE CLUTCH RETURN SPRING SUB-ASSEMBLY

- (a) Remove the reverse clutch return spring and O-ring from the reverse clutch piston.

22. INSPECT REVERSE CLUTCH RETURN SPRING SUB-ASSEMBLY (See page AT-256)

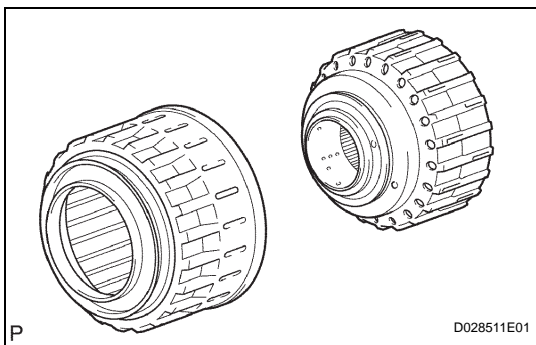

23. REMOVE REVERSE CLUTCH PISTON SUB-ASSEMBLY

- (a) Remove the reverse clutch piston sub-assembly from the clutch drum sub-assembly.

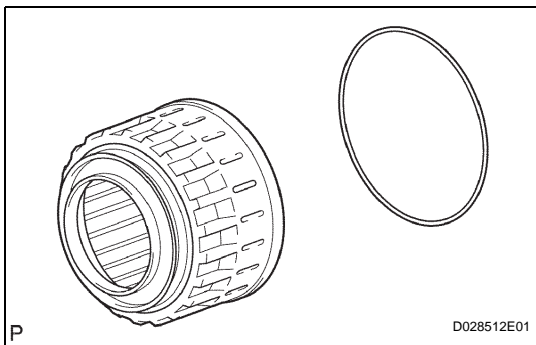

- (b) Remove the O-ring from the reverse clutch piston sub-assembly.

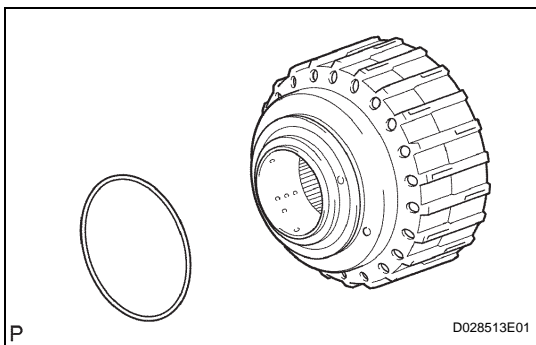

- (c) Remove the O-ring from the clutch drum sub-assembly.

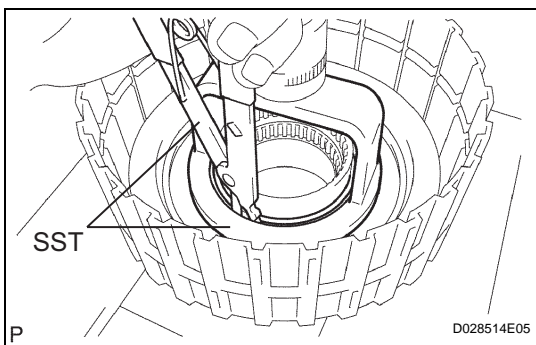

24. REMOVE DIRECT CLUTCH PISTON SUB-ASSEMBLY

- (a) Place SST on the direct clutch piston, and compress the return spring with a press.

SST 09320-89010, 09350-30020 (09350-07070)

- (b) Remove the snap ring.

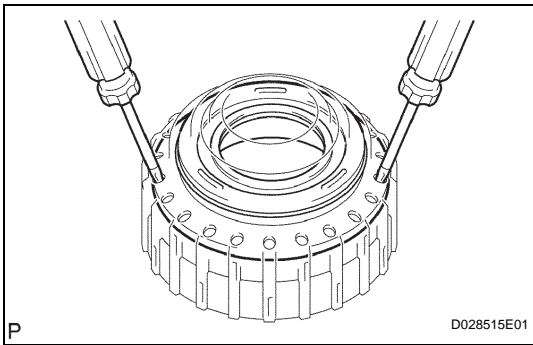

- (c) Using 2 screwdrivers, remove the direct clutch piston sub-assembly from the clutch drum.

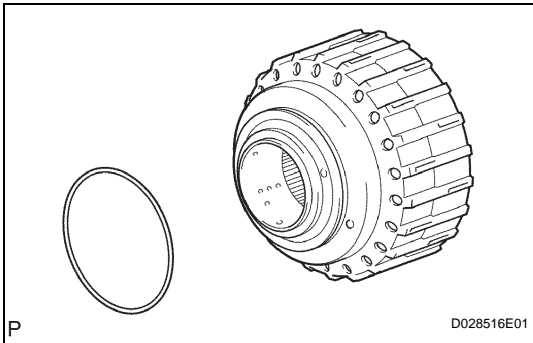

- (d) Remove the O-ring from the clutch drum.

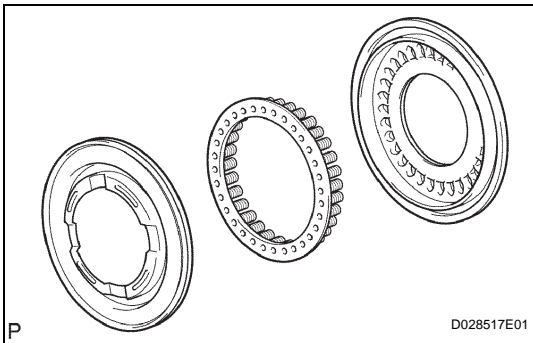

- (e) Remove the No. 2 clutch balancer and direct clutch return spring sub-assembly from the direct clutch piston sub-assembly.

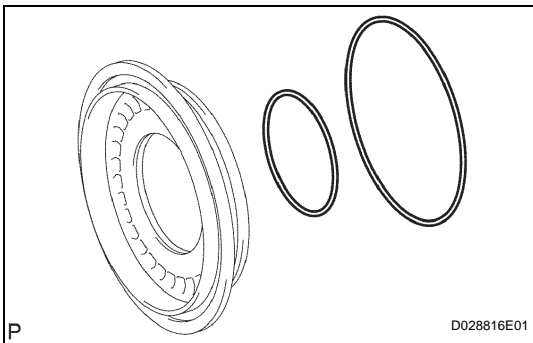

- (f) Remove the 2 O-rings from the direct clutch piston sub-assembly.

25. INSPECT DIRECT CLUTCH RETURN SPRING SUB-ASSEMBLY (See page [AT-256](#))

AT

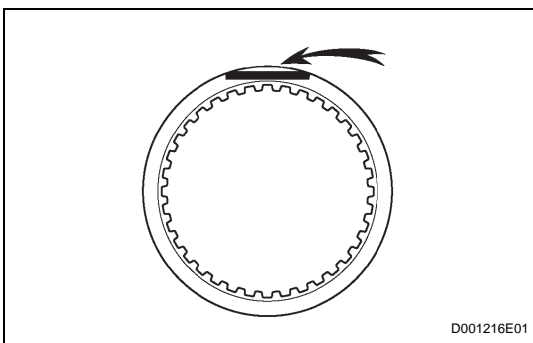

INSPECTION

1. INSPECT REAR CLUTCH DISC

- (a) Replace all discs if one of the following problems is present: 1) a disc, plate or flange is worn or burnt, 2) the lining of a disc is peeled off or discolored, or 3) grooves or printed numbers have even slight damage.

NOTICE:

Before assembling new discs, soak them in ATF for at least 15 minutes.

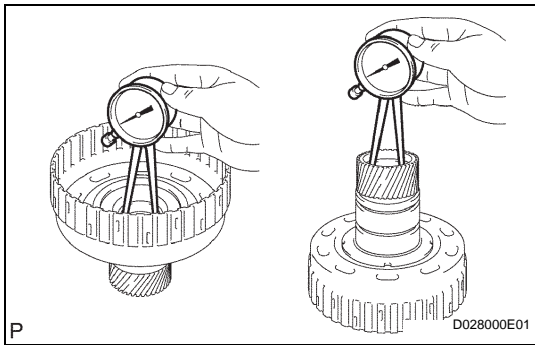

2. INSPECT REVERSE CLUTCH HUB SUB-ASSEMBLY

- (a) Using a dial indicator, measure the inside diameter of the reverse clutch hub bushing.

Standard drum bushing:

35.812 to 35.837 mm (1.4099 to 1.4109 in.)

Maximum drum bushing:

35.887 mm (1.4129 in.)

If the inside diameter is greater than the maximum, replace the reverse clutch hub.

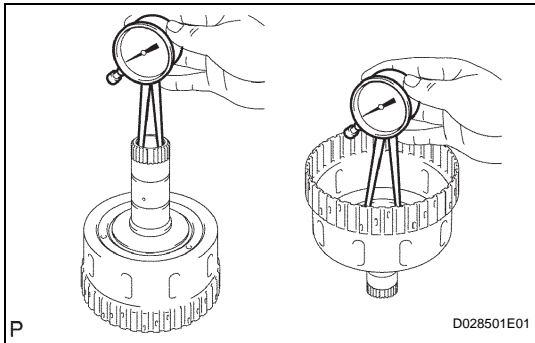

3. INSPECT FORWARD CLUTCH HUB SUB-ASSEMBLY

- (a) Using a dial indicator, measure the inside diameter of the forward clutch hub bushing.

Standard drum bushing:

26.037 to 26.062 mm (1.0251 to 1.0261 in.)

Maximum drum bushing:

26.112 mm (1.028 in.)

If the inside diameter is greater than the maximum, replace the forward clutch hub.

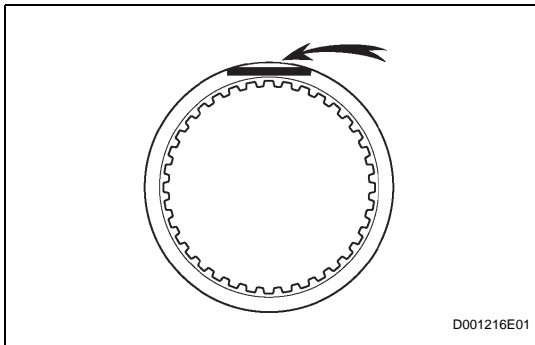

4. INSPECT FORWARD MULTIPLE DISC CLUTCH DISC

- (a) Replace all discs if one of the following problems is present: 1) a disc, plate or flange is worn or burnt, 2) the lining of a disc is peeled off or discolored, or 3) grooves or printed numbers have even slight damage.

NOTICE:

Before assembling new discs, soak them in ATF for at least 15 minutes.

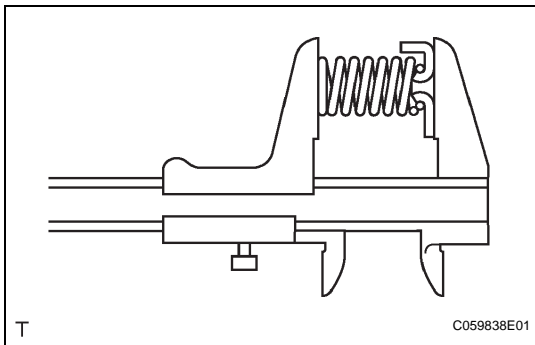

5. INSPECT FORWARD CLUTCH RETURN SPRING SUB-ASSEMBLY

- (a) Using vernier calipers, measure the free length of the spring together with the spring seat.

Standard free length:

26.74 mm (1.053 in.)

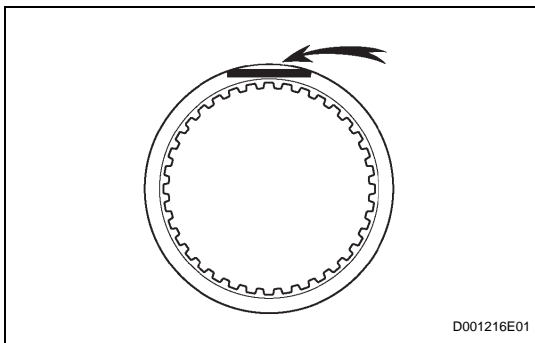

6. INSPECT DIRECT CLUTCH DISK

- (a) Replace all discs if one of the following problems is present: 1) a disc, plate or flange is worn or burnt, 2) the lining of a disc is peeled off or discolored, or 3) grooves or printed numbers have even slight damage.

NOTICE:

Before assembling new discs, soak them in ATF for at least 15 minutes.

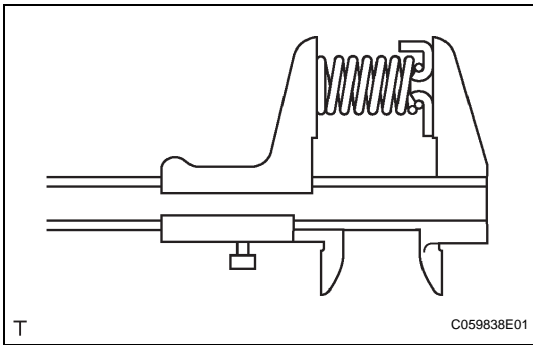

7. INSPECT REVERSE CLUTCH RETURN SPRING SUB-ASSEMBLY

- (a) Using vernier calipers, measure the free length of the spring together with the spring seat.

Standard free length:
21.04 mm (0.828 in.)

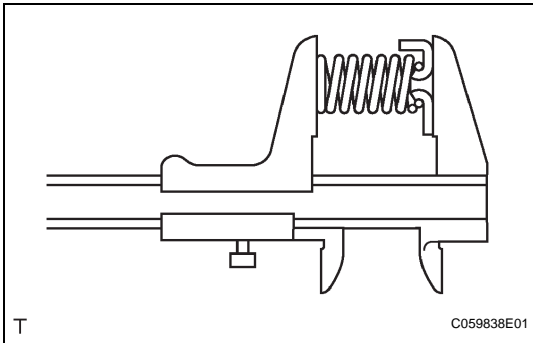

8. INSPECT DIRECT CLUTCH RETURN SPRING SUB-ASSEMBLY

- (a) Using vernier calipers, measure the free length of the spring together with the spring seat.

Standard free length:
19.51 mm (0.768 in.)

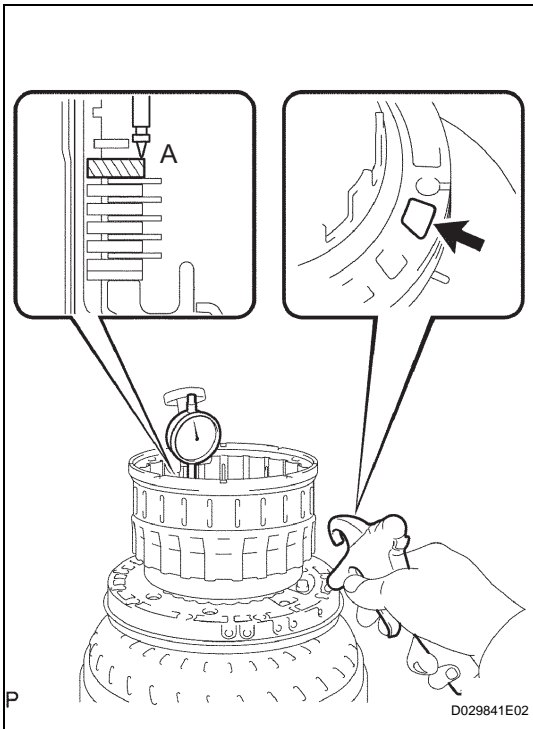

9. INSPECT PACK CLEARANCE OF DIRECT CLUTCH

- (a) Using a dial gauge, measure the moving distance (distance A) of the clutch flange at both ends across a diameter while blowing air from the oil hole as shown in the illustration, and calculate the average.

Pack clearance:
0.5 to 0.8 mm (0.020 to 0.032 in.)

NOTICE:
Install a selective flange (3.4 mm (0.134 in.)) when measuring the moving distance (shaded area in the illustration).

HINT:
 Flange moving distance A = 0.26 to 1.14 mm (0.010 to 0.045 in.)
 Pack clearance = Flange moving distance A - 0.05 mm (0.002 in.)

- (b) If the pack clearance is outside the standard, select and install a clutch flange that makes the pack clearance within the standard.

Flange thickness

No.	Thickness	No.	Thickness
0	3.0 mm (0.118 in.)	5	3.5 mm (0.138 in.)
1	3.1 mm (0.122 in.)	6	3.6 mm (0.142 in.)
2	3.2 mm (0.126 in.)	7	3.7 mm (0.146 in.)
3	3.3 mm (0.130 in.)	8	3.8 mm (0.150 in.)
4	3.4 mm (0.134 in.)	-	-

10. INSPECT PACK CLEARANCE OF REVERSE CLUTCH

- (a) Using a dial gauge, measure the reverse clutch piston stroke (distance A) and the moving distance (distance B) of the reverse flange at the both ends across a diameter while blowing air (392 kPa, 4 kgf/cm², 57 psi) from the oil hole as shown in the illustration, and calculate the average.

Pack clearance:

0.5 to 0.8 mm (0.020 to 0.032 in.)

NOTICE:

Install a selective flange (3.3 mm (0.130 in.)) when measuring the moving distance (shaded area in the illustration).

HINT:

Piston stroke A = 1.05 to 2.15 mm (0.041 to 0.085 in.)

Flange moving distance B = 0.72 to 1.08 mm (0.029 to 0.043 in.)

Pack clearance = Piston stroke A - Flange moving distance B - 0.06 mm (0.002 in.)

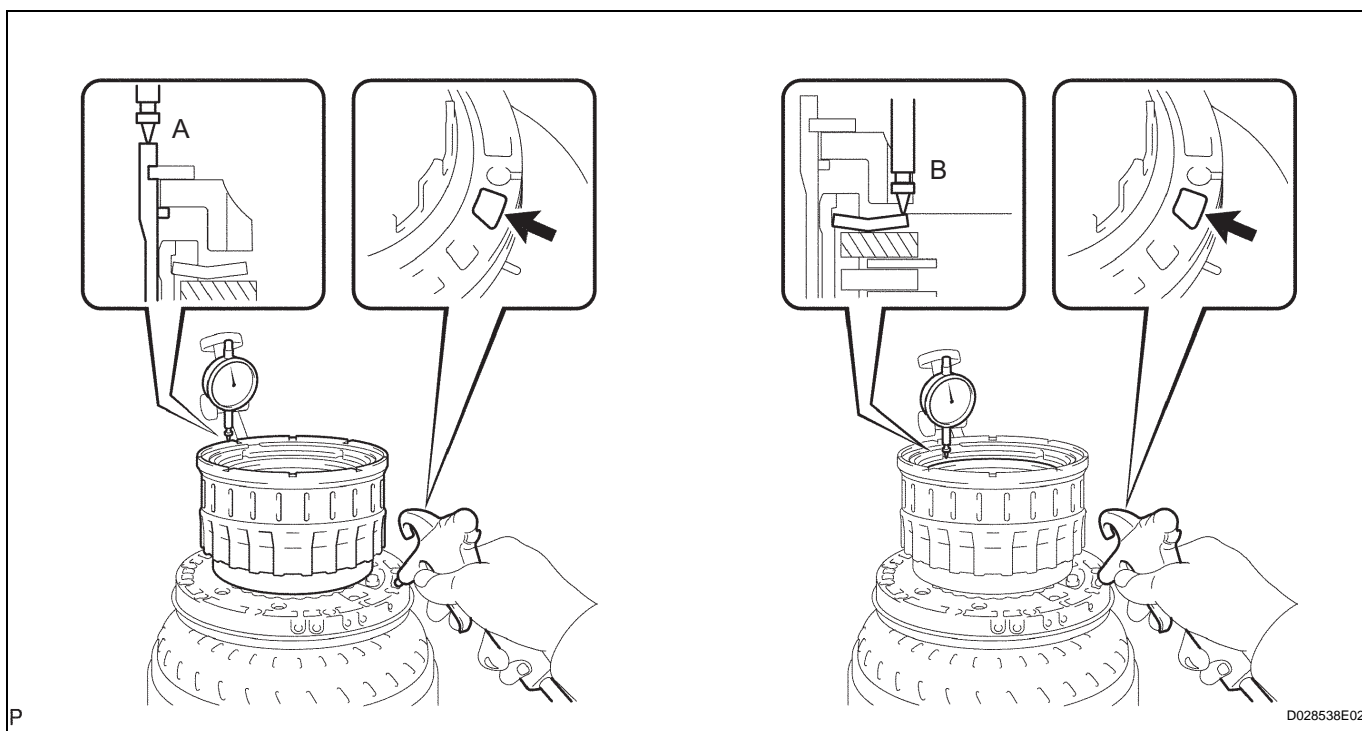

- (b) If the pack clearance is outside the standard, select and install a clutch flange that makes the pack clearance within the standard.

Flange thickness

No.	Thickness	No.	Thickness
0	2.8 mm (0.110 in.)	6	3.4 mm (0.134 in.)
1	2.9 mm (0.114 in.)	7	3.5 mm (0.138 in.)
2	3.0 mm (0.118 in.)	8	3.6 mm (0.142 in.)
3	3.1 mm (0.122 in.)	9	3.7 mm (0.146 in.)
4	3.2 mm (0.126 in.)	A	3.8 mm (0.150 in.)
5	3.3 mm (0.130 in.)		-

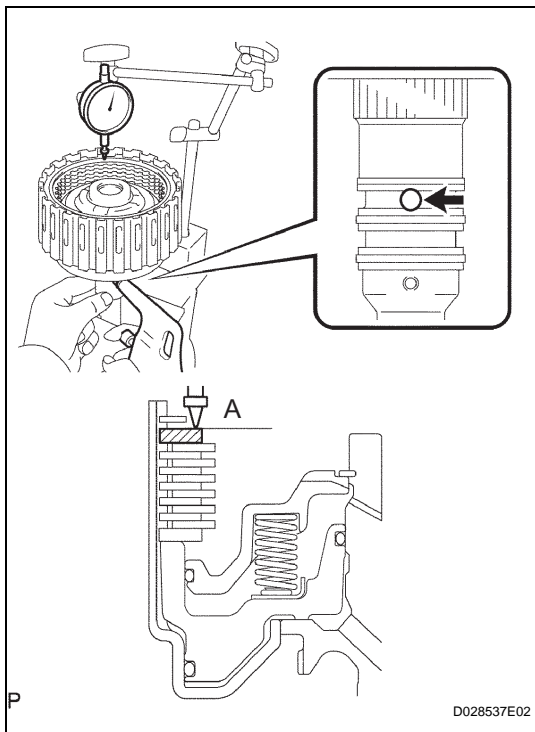

11. INSPECT PACK CLEARANCE OF FORWARD CLUTCH

- (a) Using a dial gauge, measure the moving distance (distance A) of the clutch flange at both end across a diameter while blowing air from the oil hole as shown in the illustration, and calculate the average.

Pack clearance:

0.6 to 0.9 mm (0.024 to 0.035 in.)

NOTICE:

Install a selective flange (3.4 mm (0.134 in.)) when measuring the moving distance (shaded area in the illustration).

HINT:

Flange moving distance A = 0.26 to 1.36 mm (0.010 to 0.054 in.)

Pack clearance = Flange moving distance A - 0.01 mm (0.0003 in.)

- (b) If the pack clearance is outside the standard, select and install a clutch flange that makes the pack clearance within the standard.

Flange thickness

No.	Thickness	No.	Thickness
0	3.0 mm (0.118 in.)	6	3.6 mm (0.142 in.)
1	3.1 mm (0.122 in.)	7	3.7 mm (0.146 in.)
2	3.2 mm (0.126 in.)	8	3.8 mm (0.150 in.)
3	3.3 mm (0.130 in.)	9	3.9 mm (0.154 in.)
4	3.4 mm (0.134 in.)	A	4.0 mm (0.158 in.)
5	3.5 mm (0.138 in.)		-

REASSEMBLY

1. INSTALL DIRECT CLUTCH PISTON SUB-ASSEMBLY

- (a) Coat 2 new O-rings with ATF, and install them onto the direct clutch piston.

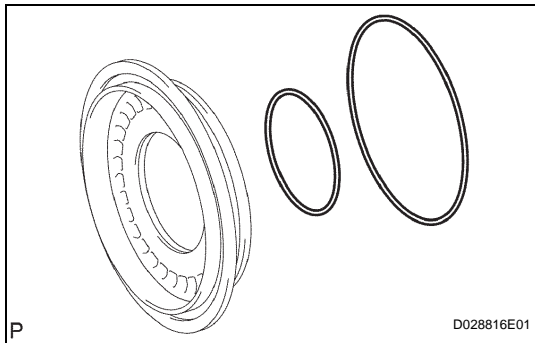

- (b) Install the No. 2 clutch balancer and direct clutch return spring onto the direct clutch piston sub-assembly.

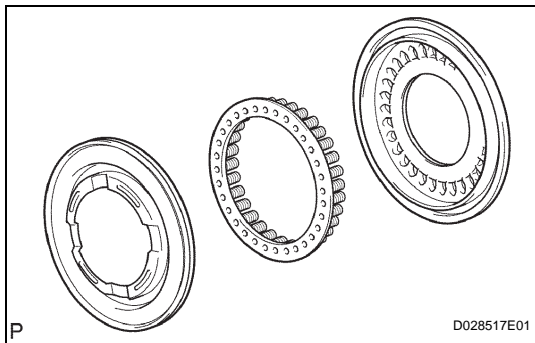

AT

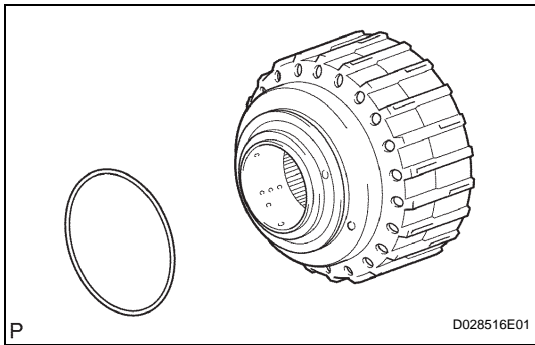

- (c) Coat a new O-ring with ATF, and install them onto the clutch drum sub-assembly.
- (d) Be careful not to damage the O-rings. Press in the direct clutch piston into the clutch drum with both hands.

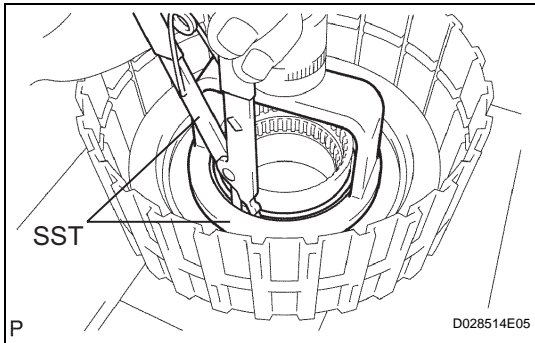

- (e) Place SST on the direct clutch piston, and compress the return spring with a press.

SST 09320-89010, 09350-30020 (09350-07070)

- (f) Install the snap ring with a snap ring expander.

NOTICE:

- Make sure that the end gap of the snap ring is not aligned with the spring retainer claw.
- Stop pressing when the spring seat is lowered to the place 1 to 2 mm (0.039 to 0.078 in.) from the snap ring groove to prevent the spring seat from being deformed.
- Do not expand the snap ring excessively.

- (g) Set the end gap of the snap ring in the piston as shown in the illustration.

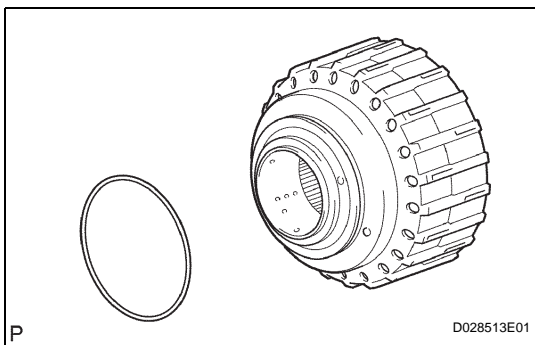
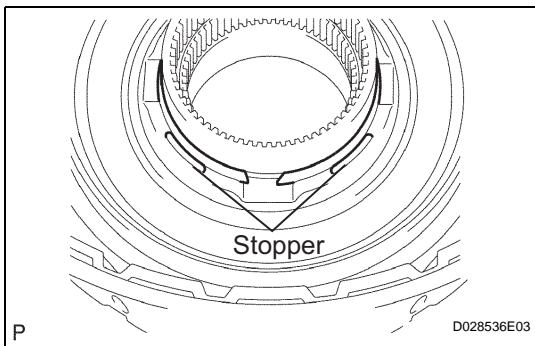

2. INSTALL REVERSE CLUTCH PISTON SUB-ASSEMBLY

- (a) Coat a new O-ring with ATF, and install it onto the clutch drum sub-assembly.

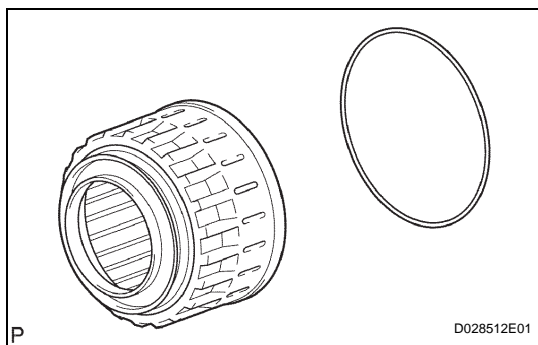

- (b) Coat a new O-ring with ATF, and install it onto the reverse clutch piston sub-assembly.

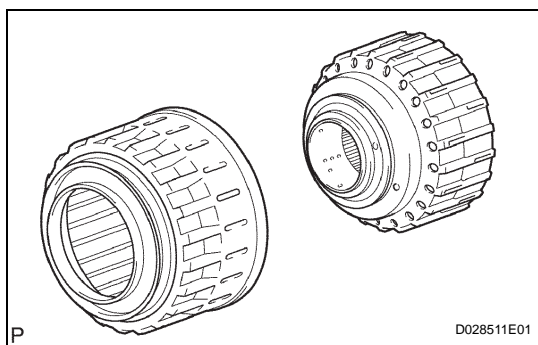

- (c) Be careful not to damage the O-ring. Press in the clutch drum sub-assembly into the reverse clutch piston with both hands.

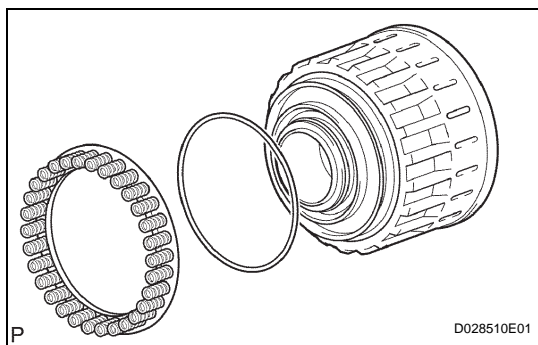

3. INSTALL REVERSE CLUTCH RETURN SPRING SUB-ASSEMBLY

- (a) Coat a new O-ring with ATF, and install it onto the reverse clutch piston sub-assembly.
 (b) Install the reverse clutch return spring onto the reverse clutch piston sub-assembly.

AT

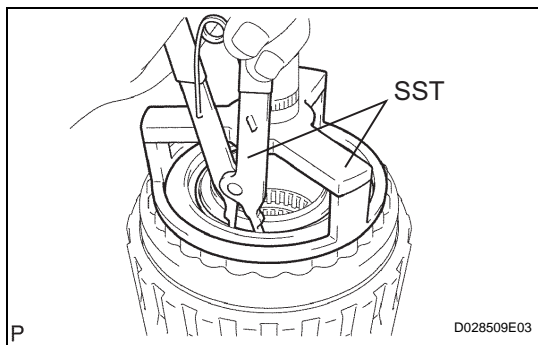

4. INSTALL NO. 3 CLUTCH BALANCER

- (a) Place SST on the No. 3 clutch balancer, and compress the return spring with a press.
SST 09387-00070, 09350-30020 (09350-07070)
 (b) Install the snap ring with a snap ring expander.
 (c) Make sure that the end gap of the snap ring is not aligned with the spring retainer claw.

NOTICE:

- Stop pressing when the spring seat is lowered to the place 1 to 2 mm (0.039 to 0.078 in.) from the snap ring groove to prevent the spring seat from being deformed.
- Do not expand the snap ring excessively.

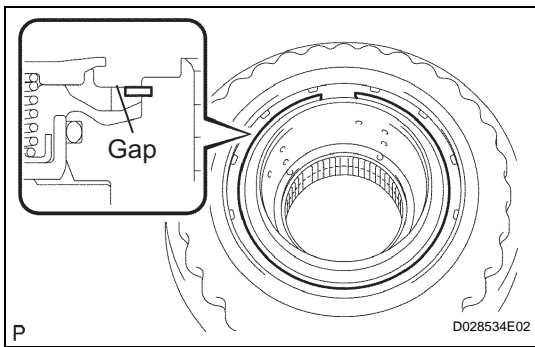

- (d) Set the end gap of the snap ring in the piston as shown in the illustration.

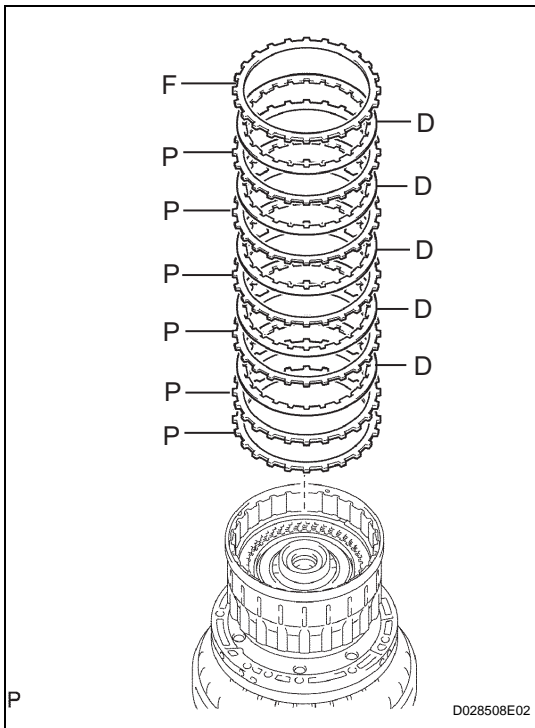

5. INSTALL DIRECT CLUTCH DISK

- (a) Install the reverse clutch flange, 6 plates and 5 discs onto the clutch drum sub-assembly.

Install in order:

P - P - D - P - D - P - D - P - D - P - D - F

HINT:

P = Plate, D = Disc, F = Flange

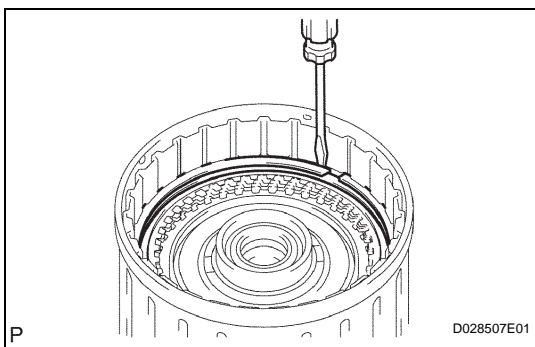

- (b) Using a screwdriver, install the 2 hole snap rings onto the clutch drum sub-assembly.

6. INSPECT PACK CLEARANCE OF DIRECT CLUTCH
(See page [AT-256](#))

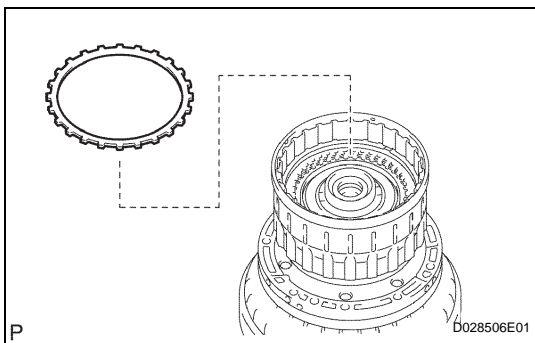

7. INSTALL REVERSE CLUTCH FLANGE

- (a) Install the reverse clutch flange onto the clutch drum sub-assembly.

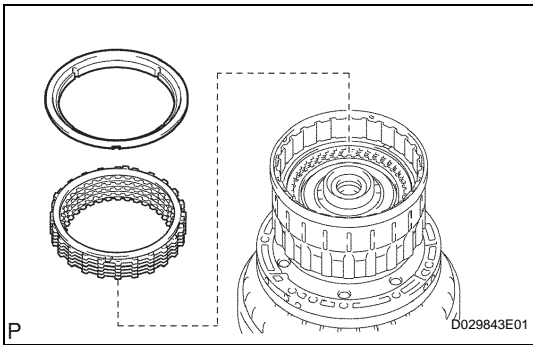

8. INSTALL REVERSE CLUTCH REACTION SLEEVE

- (a) Install the reverse clutch reaction sleeve, clutch cushion plate, reverse clutch flange, 5 reverse clutch discs, and 4 clutch plates onto the reverse clutch hub.
- (b) Using a screwdriver, install the hole snap ring.

9. INSPECT PACK CLEARANCE OF REVERSE CLUTCH (See page AT-257)

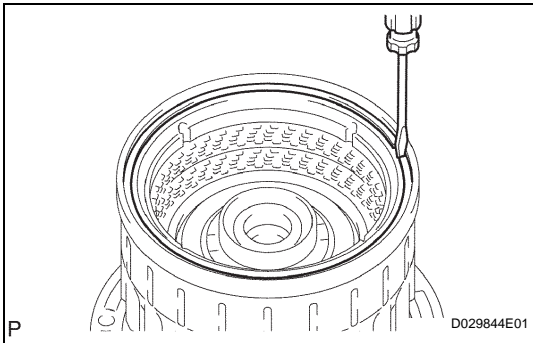

10. REMOVE REVERSE CLUTCH REACTION SLEEVE

- (a) Using a screwdriver, remove the snap ring from the clutch drum assembly.

- (b) Remove the reverse clutch reaction sleeve, clutch cushion plate, reverse clutch flange, 5 reverse clutch discs, and 4 clutch plates from the reverse clutch hub sub-assembly.

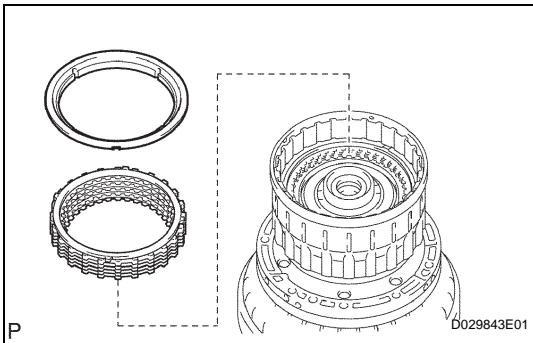

11. INSTALL FORWARD CLUTCH PISTON

- (a) Coat 2 new O-rings with ATF, and install them onto the No. 1 forward clutch piston.

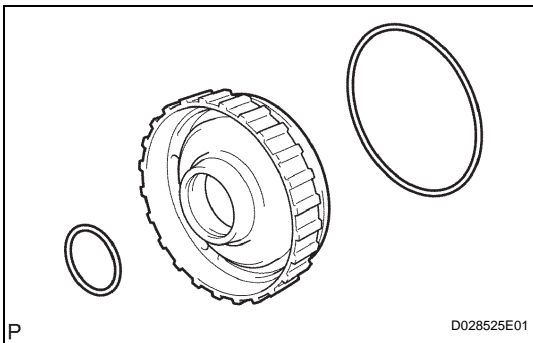

12. INSTALL NO. 1 CLUTCH BALANCER

- (a) Coat a new O-ring with ATF and install it onto the clutch balancer.

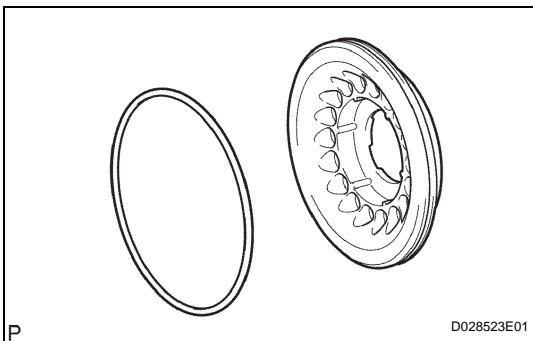

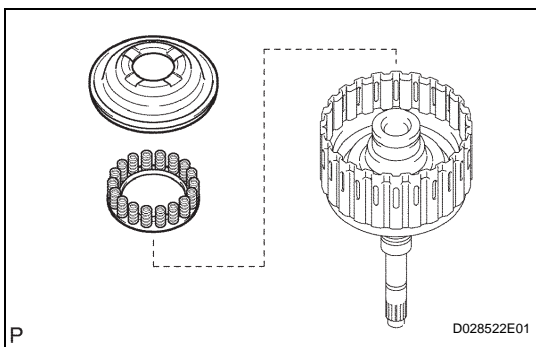

- (b) Install the No. 1 clutch balancer and forward clutch return spring sub-assembly.

NOTICE:

Be careful not to damage the O-ring.

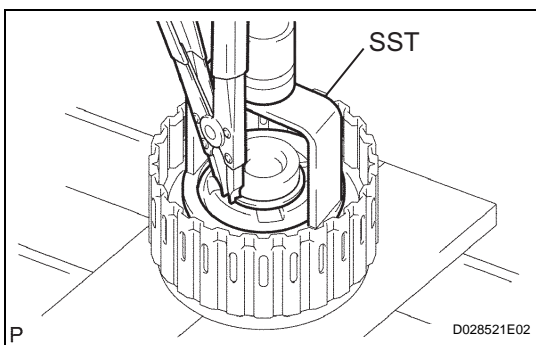

- (c) Place SST on the No. 1 clutch balancer, and compress the return spring with a press.

SST 09350-30020 (09350-07040, 09350-07070)

- (d) Install the snap ring with a snap ring expander.

- (e) Make sure that the end gap of the snap ring is not aligned with the spring retainer claw.

NOTICE:

- **Stop pressing when the spring seat is lowered to the place 1 to 2 mm (0.039 to 0.078 in.) from the snap ring groove to prevent the spring seat from being deformed.**
- **Do not expand the snap ring excessively.**

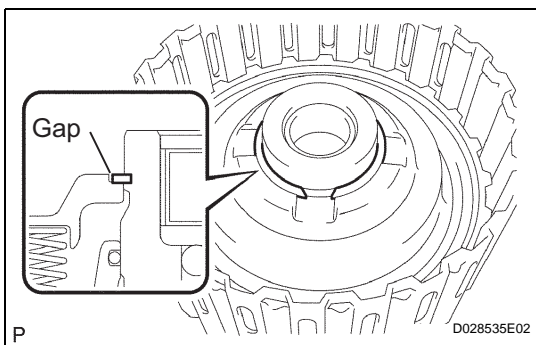

- (f) Set the end gap of the snap ring in the piston as shown in the illustration.

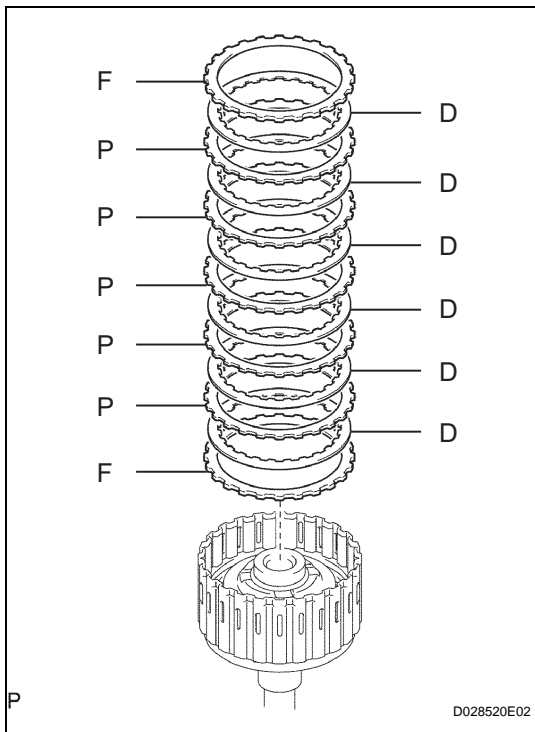

13. INSTALL FORWARD MULTIPLE DISC CLUTCH DISC

- (a) Install the 2 flanges, 6 discs and 5 plates onto the input shaft assembly.

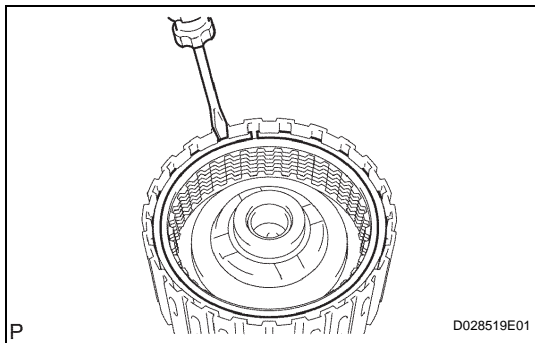

- (b) Install in order:

F - D - P - D - P - D - P - D - P - D - P - D - F

HINT:

P = Plate, D = Disc, F = Flange

Using a screwdriver, install the hole snap ring.

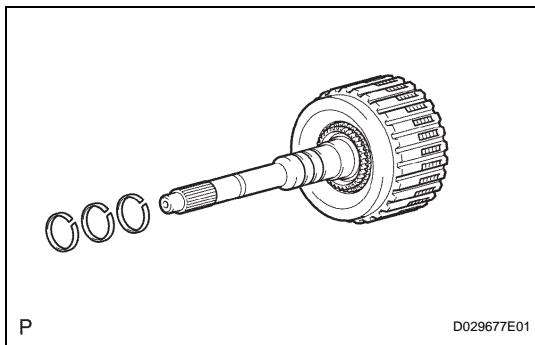

14. INSTALL INPUT SHAFT OIL SEAL RING

- (a) Coat the 3 oil seal rings with ATF.
 (b) Put together the ends of the 3 oil seal rings together, and then install them onto the stator shaft groove.

NOTICE:

Do not over-widen the ring ends.

HINT:

After installing the oil seal rings, check that they rotate smoothly.

15. INSPECT PACK CLEARANCE OF FORWARD CLUTCH (See page AT-258)

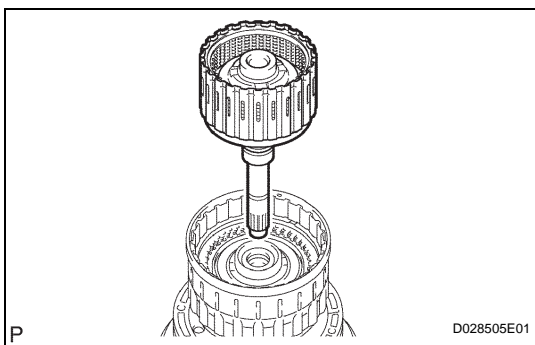

16. INSTALL INPUT SHAFT ASSEMBLY

- (a) Install the input shaft assembly onto the clutch drum.

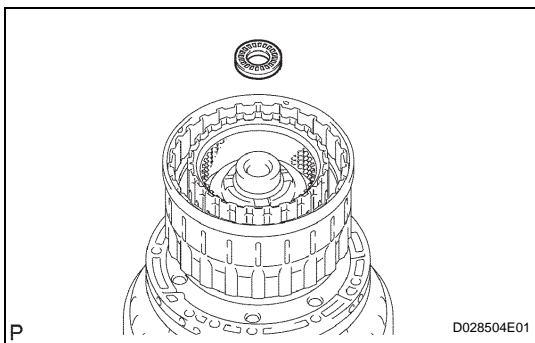

- (b) Install the thrust needle roller bearing onto the clutch drum assembly.

Thrust needle roller bearing diameter

Item	Inside	Outside
Thrust needle roller bearing	21.3 mm (0.839 in.)	41.1 mm (1.618 in.)

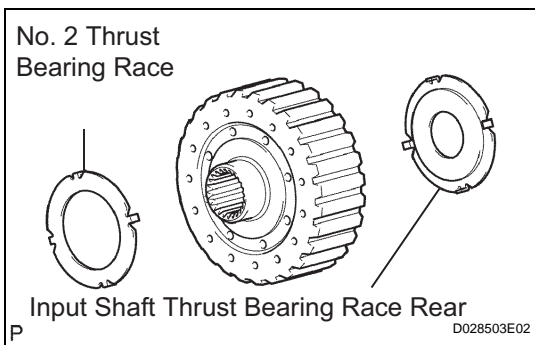

17. INSTALL MULTIPLE DISC CLUTCH HUB

- (a) Install the No. 2 thrust bearing race and input shaft thrust bearing race rear onto the multiple disc clutch hub.

Bearing and race diameter

Item	Inside	Outside
Thrust bearing race No. 2	38.4 mm (1.512 in.)	63.0 mm (2.480 in.)
Input shaft bearing race RR	22.6 mm (0.890 in.)	60.0 mm (2.362 in.)

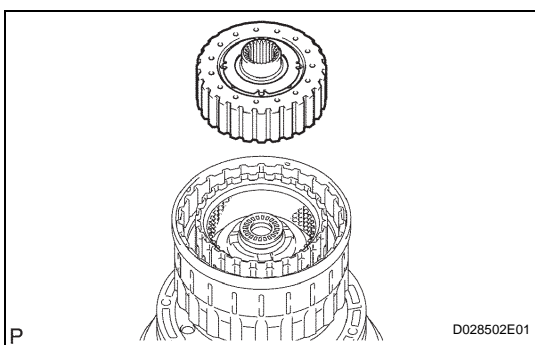

- (b) Install the multiple disc clutch hub into the clutch drum assembly.

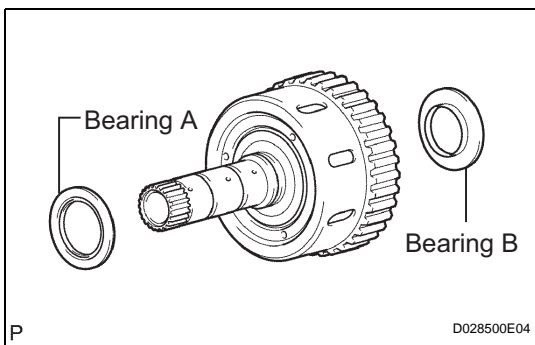

18. INSTALL FORWARD CLUTCH HUB SUB-ASSEMBLY

- (a) Install the 2 thrust needle roller bearings onto the forward clutch hub sub-assembly.

Bearing and race diameter

Item	Inside	Outside
Bearing A	42.5 mm (1.673 in.)	61.2 mm (2.409 in.)
Bearing B	33.3 mm (1.311 in.)	56.6 mm (2.228 in.)

AT

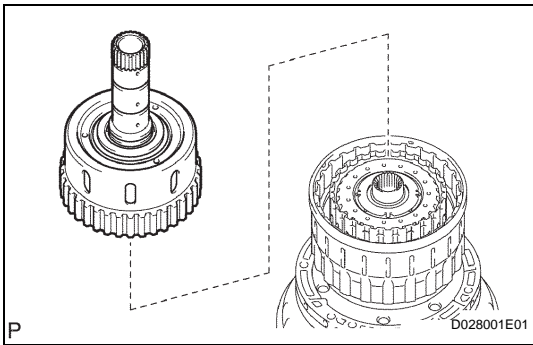

- (b) Install the forward clutch hub sub-assembly onto the clutch drum assembly.

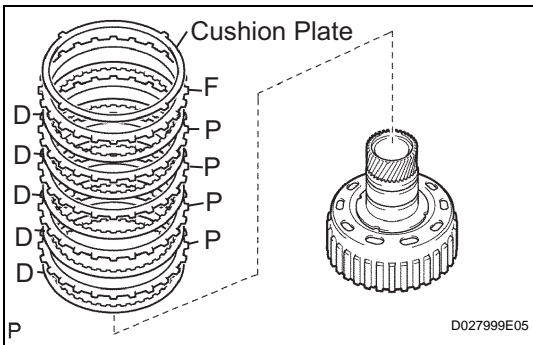

19. INSTALL REAR CLUTCH DISC

- (a) Install the clutch cushion plate, reverse clutch flange, 4 plates and 5 discs onto the reverse clutch hub.

Install in order:

D - P - D - P - D - P - D - P - D - F

HINT:

P = Plate, D = Disc, F = Flange

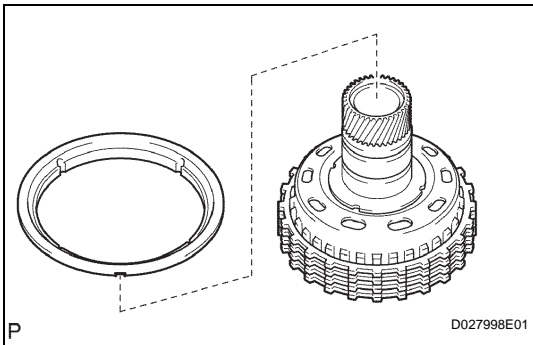

20. INSTALL REVERSE CLUTCH REACTION SLEEVE

- (a) Install the reverse clutch reaction sleeve onto the reverse clutch hub.

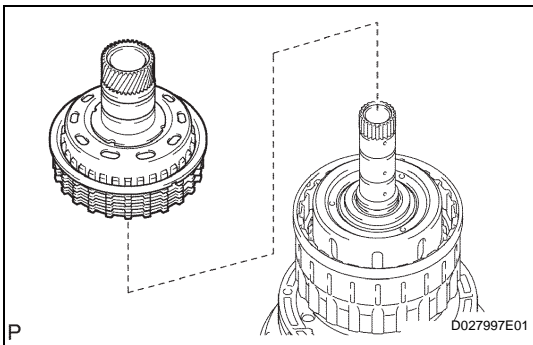

21. INSTALL REVERSE CLUTCH HUB SUB-ASSEMBLY

- (a) Install the reverse clutch hub sub-assembly, reverse clutch reaction sleeve, clutch cushion plate, reverse clutch flange, 5 reverse clutch discs, and 4 clutch plates onto the clutch drum assembly.

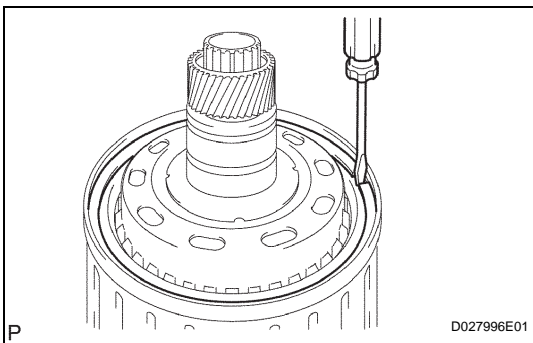

- (b) Using a screwdriver, install the snap ring onto the clutch drum and input shaft assembly.